

Part Number	A	B	C	Hughes
S-11-Mo-A.010B.010C.015D.0015	0.010	0.010	0.015	
S-11-Mo-A.015B.015C.030D.0015	0.015	0.015	0.030	GW011-3A
S-11-Mo-A.0205B.020C.035D.003	0.020	0.020	0.035	GW011-2A
S-11-Mo-A.025B.025C.045D.005	0.025	0.025	0.045	GW011-1A
S-11-	?	?	?	

Standard Material:
Molybdenum (Mo)

Part Number Construction
S-11-Mo-A.010B.010C.015 -D.0015

Spacer Selection
 .0015
 .003
 .005

Dimensions
 Material
 Product Series

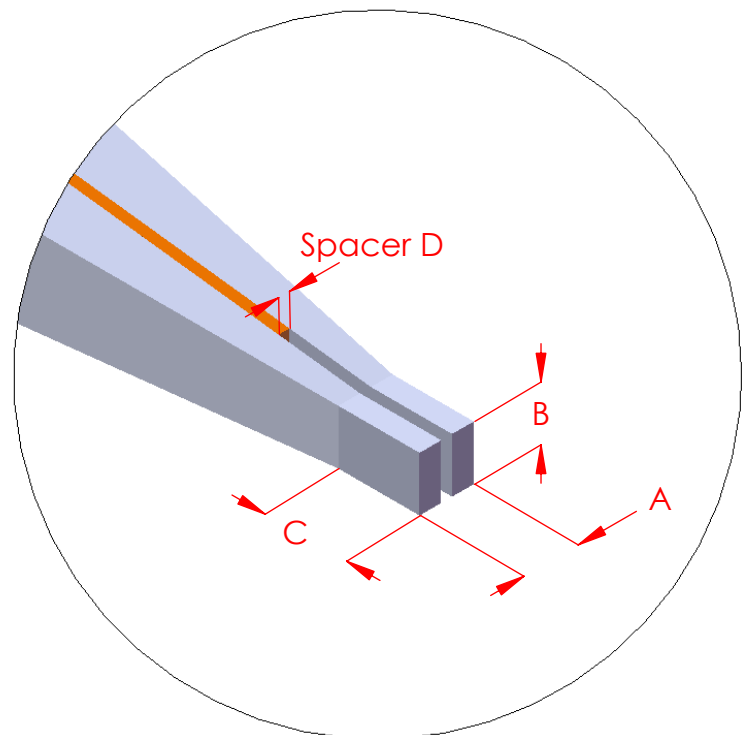

DETAIL VIEW F
SCALE 40 : 1

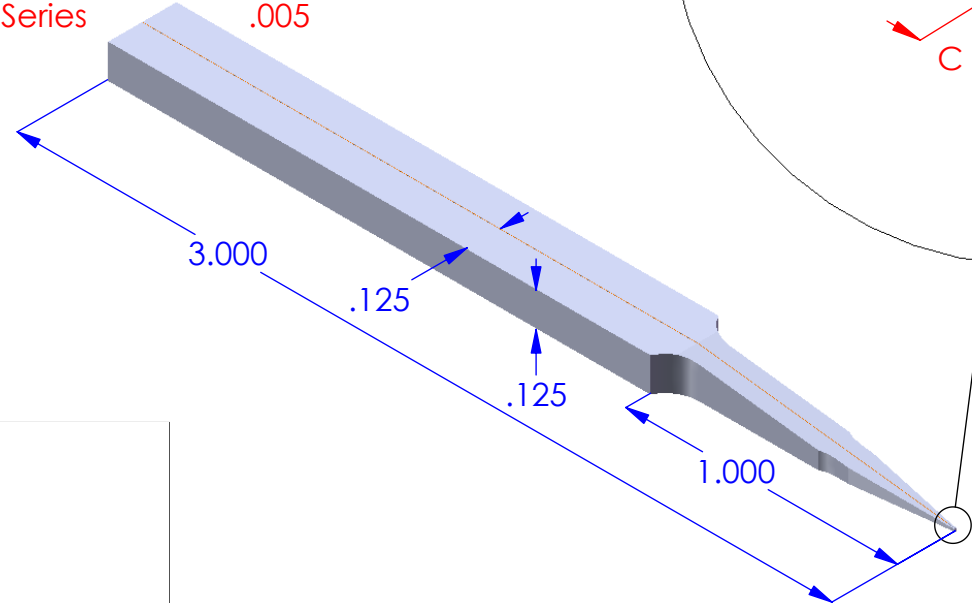

**Custom configurations and Materials available.
Contact the factory for assistance.**

AIT PROPRIETARY THIS DOCUMENT AND THE DATA DISCLOSED HEREIN OR HEREWITH IS NOT TO BE REPRODUCED, USED OR DISCLOSED IN WHOLE OR IN PART TO ANYONE WITHOUT WRITTEN PERMISSION OF AIT		SIGNATURE DRAWN CHECKED ENGINEER	DATE	ADVANCED INTEGRATED TECHNOLOGIES INC.	
MC THIRD ANGLE PROJECTION 		DESCRIPTION		SIZE JOB NUMBER DRAWING NUMBER REV A S-11 A	
3D		DO NOT SCALE DRAWING		SCALE: 1/1	SHT 1 OF 1